

PLANTA ALTA

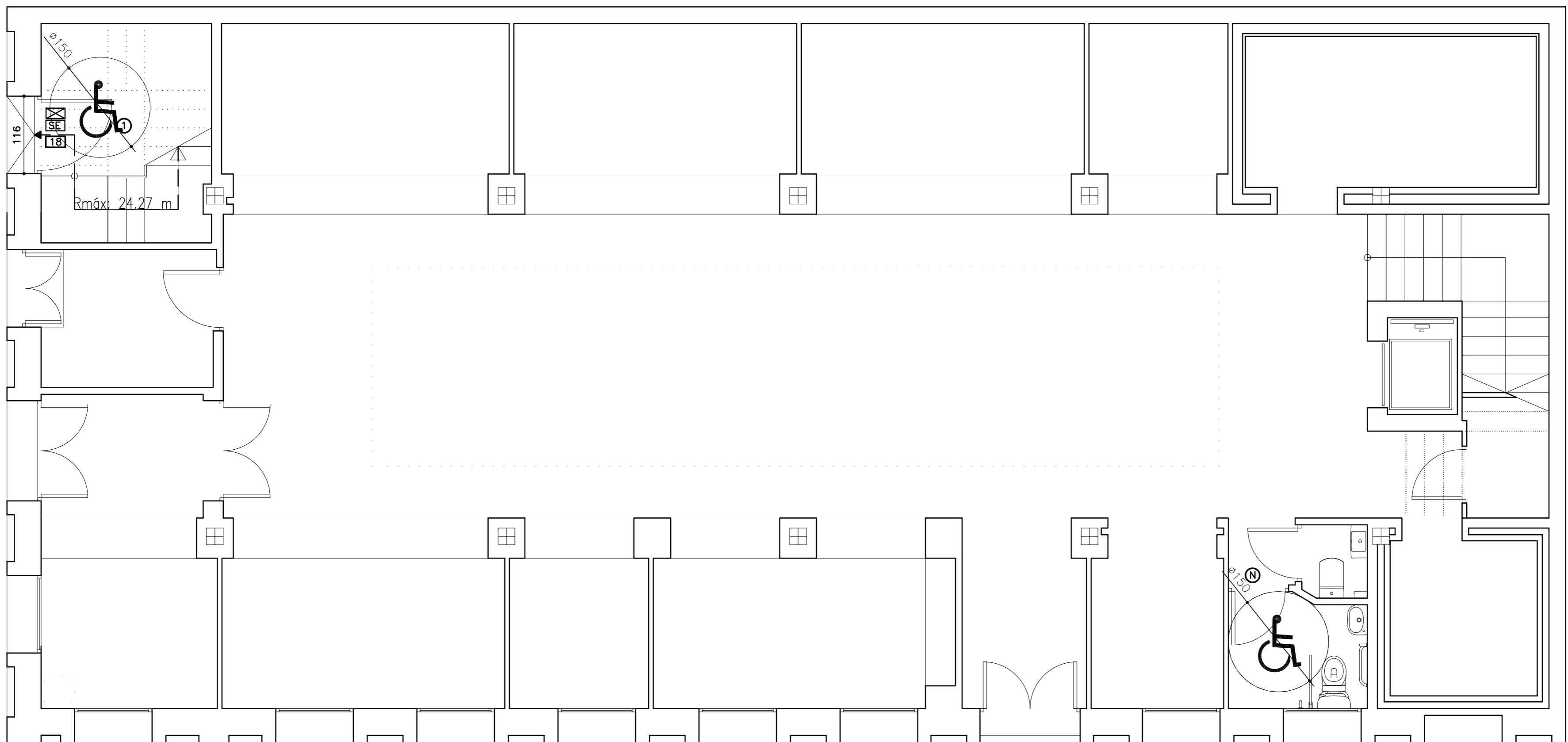

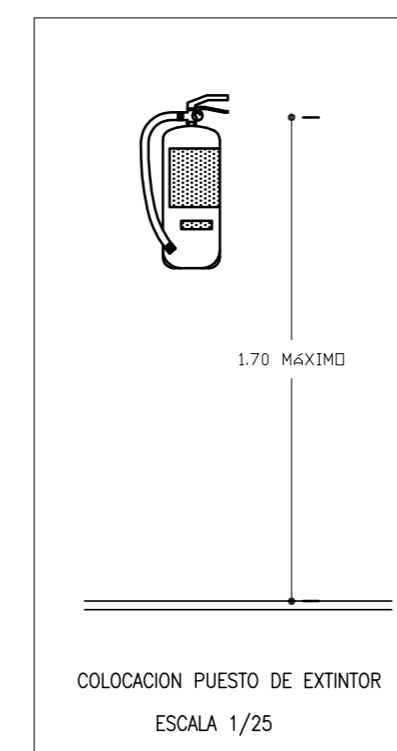

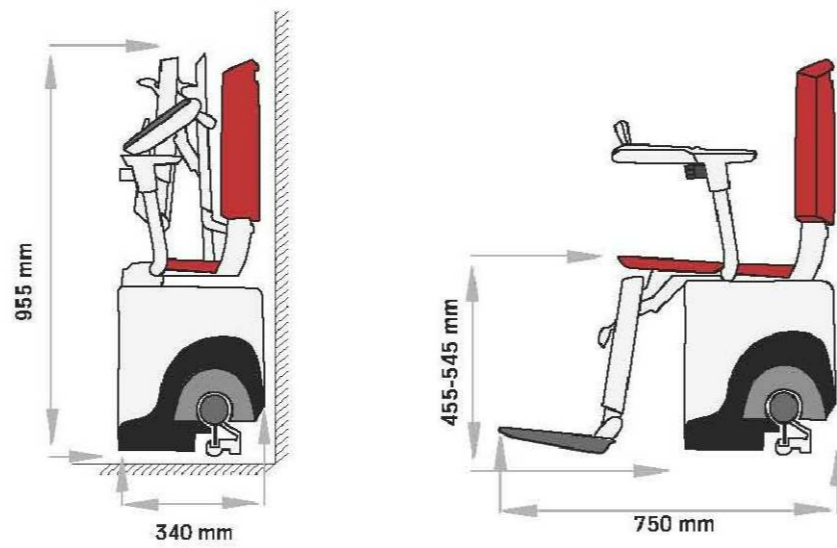

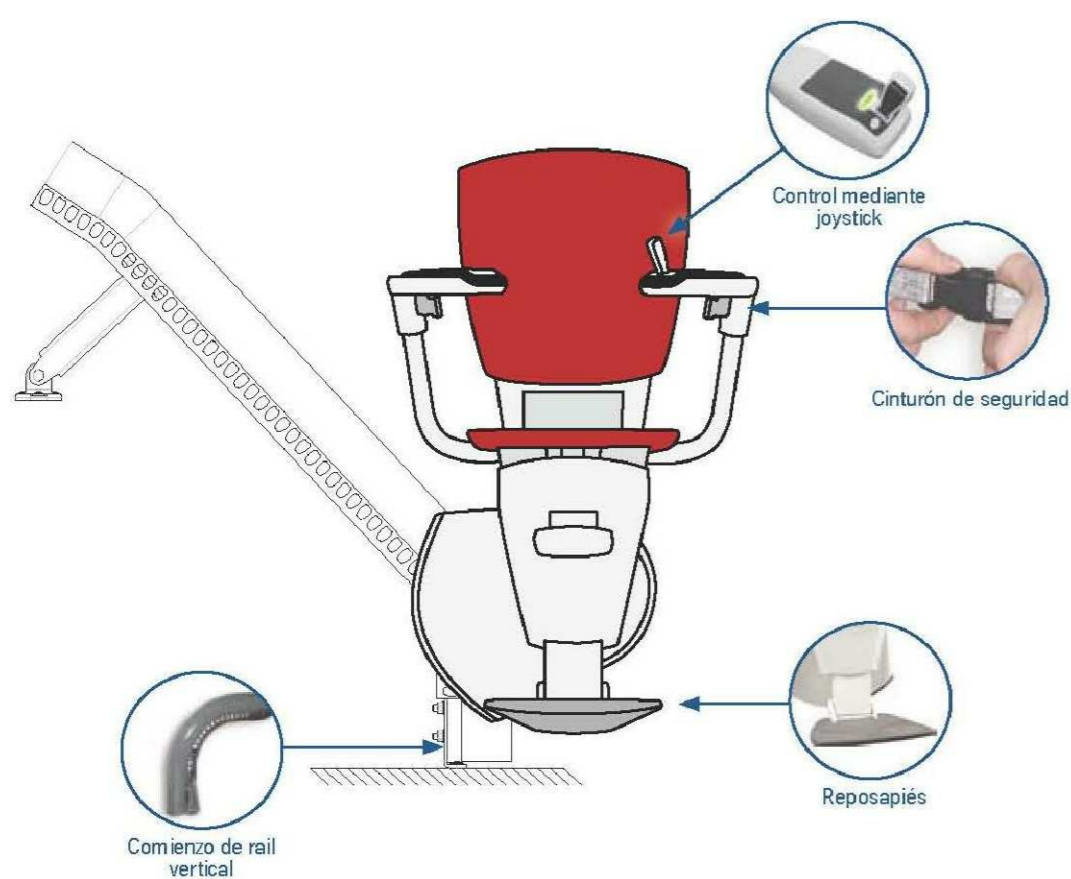



PLANTA BAJA

 NO SE INTERVIENE



LEYENDA CONTRAINCENDIOS

- RECORRIDO DE EVACUACIÓN
-  INDICATIVO SALIDA DE EMERGENCIA
-  ALUMBRADO DE EMERGENCIA
-  INDICATIVO DIRECCION DE SALIDA
-  INDICATIVO NO HAY SALIDA
-  EXTINTOR 21A-113B
-  DETECTOR DE HUMO
-  OCUPACIÓN (N: NULA)
-  ACUMULACIÓN DE OCUPANTES
-  BOCA DE INCENDIOS EQUIPADA

DETALLE TIPO SALVAESCALERAS
(Se colocará en la escalera de nuevo acceso a planta alta)

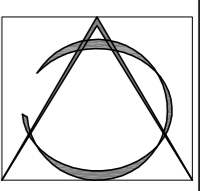
	PROYECTO BÁSICO Y EJECUCIÓN DE ADECUACIÓN DE PLANTA ALTA DEL MERCADO MUNICIPAL PARA DEPENDENCIAS MUNICIPALES EN C/ STA. M ^a SALOMÉ, N ^o 10. BONARES (HUELVA)	
Arquitectos:	Montserrat Carrasco Carrasco	Feb./09
Propiedad:	ILMO. AYUNTAMIENTO DE BONARES	Escala:
Plano:	ACCESIBILIDAD. SEGURIDAD EN CASO DE INCENDIOS	1/50
		N ^o Plano: 10